

Velodyne Lidar[®] HDL-32E

HIGH RESOLUTION REAL-TIME 3D LIDAR SENSOR



HDL-32E



Stylishly small and ruggedly built with an unrivaled field of view, Velodyne's HDL-32E Lidar sensor was designed to exceed the demands of the most challenging, real-world industrial applications including autonomous vehicle control and operation, mobile terrestrial mapping, aerial 3D mapping and security surveillance.

The HDL-32E measures only 144 mm by 85 mm and weighs 1.0 kg (plus 0.3 kg for cabling). Its compact size and weight makes it ideal for all Lidar applications, in particular those with constrained form factors and pricing requirements but still demand high performance.

Unprecedented Field of View and Point Density

The HDL-32E's innovative multi-channel array enables navigation and mapping systems to observe more of their environment than any other Lidar sensor. The HDL-32E utilizes 32 Lidar channels aligned from +10.67° to -30.67° to provide an unmatched vertical field of view, and its patented rotating head design delivers a real-time 360° horizontal field of view. The HDL-32E generates a point cloud of up to 695,000 points per second with a range of up to 100 m and a typical accuracy of ±2 cm. The resulting comprehensive point cloud coverage within a single data stream makes the HDL-32E an indispensable part of any sensor suite.



DIMENSIONS

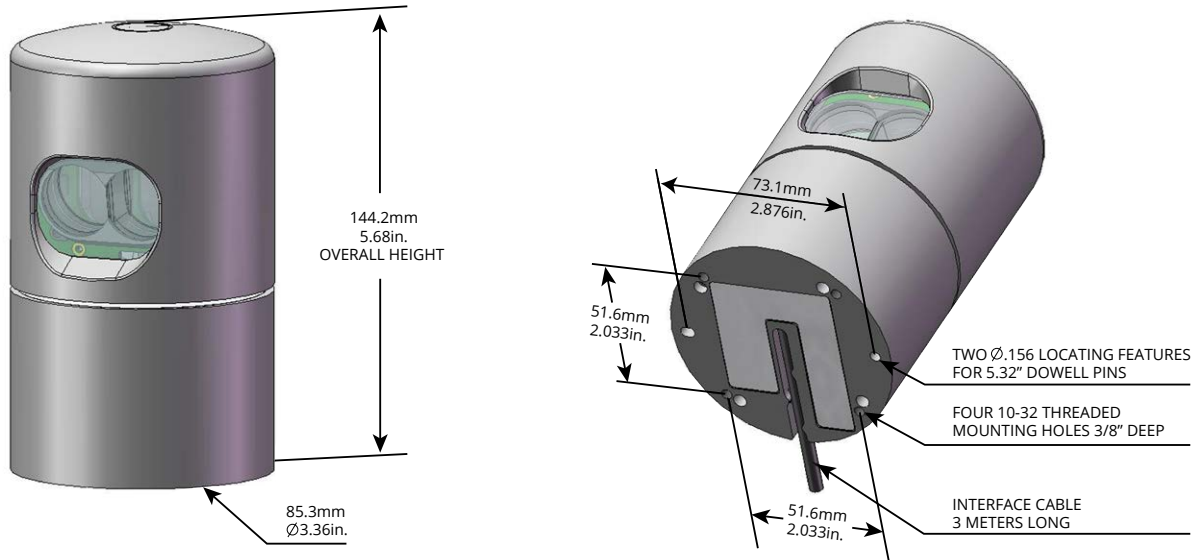

M12 CONNECTOR OPTION

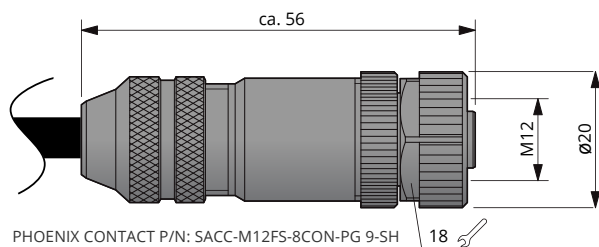

For other connector options contact
Velodyne Sales (sales@velodyne.com)



High Definition Real-Time 3D Lidar Sensor

The HDL-32E provides high definition 3-dimensional information about the surrounding environment.

Specifications:

Sensor:

- 32 Channels
- Measurement Range: Up to 100 m
- Range Accuracy: Up to ± 2 cm (Typical)¹
- Single and Dual Returns (Strongest, Last)
- Field of View (Vertical): $+10.67^\circ$ to -30.67° (41.33°)
- Angular Resolution (Vertical): 1.33°
- Field of View (Horizontal): 360°
- Angular Resolution (Horizontal/Azimuth): 0.08° - 0.33°
- Rotation Rate: 5 Hz – 20 Hz
- Integrated Web Server for Easy Monitoring and Configuration

Laser:

- Laser Product Classification: Class 1 Eye-safe per IEC 60825-1:2007 & 2014
- Wavelength: 903 nm

Mechanical/ Electrical/ Operational

- Power Consumption: 12 W (Typical)²
- Operating Voltage: 9 V – 18 V (with Interface Box and Regulated Power Supply)
- Weight: ~ 1.0 kg (without Cabling and Interface Box)
- Dimensions: See diagram on previous page
- Environmental Protection: IP67
- Operating Temperature: -10°C to $+60^\circ\text{C}$ ³
- Storage Temperature: -40°C to $+105^\circ\text{C}$

Output:

- 3D Lidar Data Points Generated:
 - Single Return Mode: $\sim 695,000$ points per second
 - Dual Return Mode: $\sim 1,390,000$ points per second
- 100 Mbps Ethernet Connection
- UDP Packets Contain:
 - Time of Flight Distance Measurement
 - Calibrated Reflectivity Measurement
 - Rotation Angles
 - Synchronized Time Stamps (μs resolution)
- Orientation: 6DoF Inertial Sensor Measurements
- GPS: \$GPRMC and \$GPGGA NMEA Sentences from GPS Receiver (GPS not included)

97-0038 Rev-N

For more details and ordering information, contact Velodyne Sales (sales@velodyne.com)

1. Typical accuracy refers to ambient wall test performance across most channels and may vary based on factors including but not limited to range, temperature and target reflectivity.
2. Operating power may be affected by factors including but not limited to range, reflectivity and environmental conditions.
3. Operating temperature may be affected by factors including but not limited to air flow and sun load.



CLASS 1 LASER PRODUCT

Specifications are subject to change. Banner image courtesy of Ford Motor Co. Other trademarks or registered trademarks are property of their respective owners.

Copyright ©2019 Velodyne Lidar, Inc.